

ROLL-UP DOOR SYSTEMS WITH METAL MESH

SPECIFICATIONS

CONTENTS

02 ROLLER SHUTTERS MADE OF METAL MESH

03 MESH TYPES

04 DIFFERENCES BETWEEN THE SYSTEMS

05 EXTERNAL MOTOR

06 The GFA TS 959 standard control system

08 Installation dimensions: GFA TS 959 control system

09 Installation dimensions: guides

10 Space requirement: external motor

11 Brackets

12 Reference value table for external motor Lago mesh

13 Reference value table for external motor Sambesi mesh

14 Reference value table for external motor Tigris mesh

15 Guides and bottom door edge

16 TUBE MOTOR

17 Installation dimensions: guides

18 Space requirement: tube motor

19 Brackets

20 Reference value table for tube motor Lago mesh

21 Reference value table for tube motor Sambesi mesh

22 Reference value table for tube motor Tigris mesh

23 Guides and bottom door edge

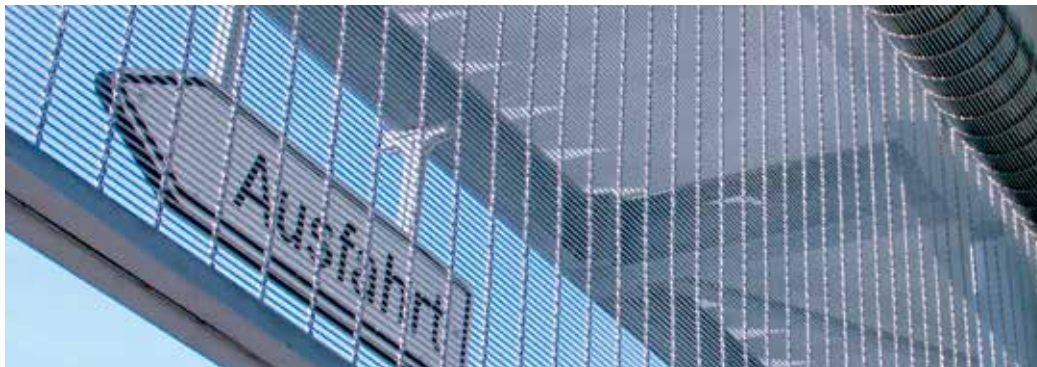

Subject to technical modifications. No liability for printing errors. All colors shown are subject to print-based deviations. Text and images can show special equipment that is not included as standard.

Any copying, distribution or utilization of this document, as well as any communication of its content to others, is prohibited unless express authorization has been granted. Any violations will result in an obligation to provide compensation for damages. All rights reserved with regard to patent claims or submission of design or utility patents.

Abbreviations

AS	Height above lintel: external motor
AS-DMS	Height above lintel: external motor with DMS
DMS	Torque support (vertical motor installation)
ET-A	Installation depth: external motor incl. brackets
ET-DMS	Installation depth: external motor with DMS
ET-R	Installation depth: tube motor
FR	Stop width: safety gear for tube motor
FS	Guide rail width
KUA	Bracket dimension: motor side
KUL	Bracket dimension: bearing side
LA	Stop width: bearing side for external motor
MR	Stop width: motor side for tube motor
MS-A	Stop width: motor side for external motor
MS-DMS	Stop width: motor side for external motor with DMS
OKW	Top edge of shaft
RS	Height above lintel: tube motor
SSB	Height above lintel with sloping floor
VO	Possible height offset: move attachment point upward
W	Shaft diameter in mm

FUNCTION, SAFETY AND AESTHETICS – ROLLER SHUTTERS MADE OF METAL MESH



To date, secure shutter solutions in shopping arcades, underground car parks or kiosks have rarely offered appealing aesthetics. With the typical transparency of metal mesh, the new roll-up door and roller shutter system made of stainless steel mesh from GKD combines aesthetics with maximum functionality. Standing five meters high and up to eight meters wide, the transparent and air-permeable stainless steel design can be used both outdoors and indoors and is virtually maintenance-free. The roll-up doors and roller shutters, produced to European safety standards from high-grade stainless steel, are weather-resistant and easy to look after. The system therefore not only delivers a high degree of functional reliability, but also offers a long service life and low maintenance costs. Despite its elegant design, the mesh is tough and the stable roll-up doors and roller shutters

reliably prevent unauthorized access and theft. At the same time, they guarantee optimum ventilation and an unrestricted view of the areas they protect. Individually matched lighting concepts control the transparency of the mesh and create targeted accents through reflections. GKD can supply a complete solution from a single source, including mesh, motor, guide rails, end profiles and wall switches. As they are perfectly matched to one another and easy to install, the system components ensure that everything is up and running quickly. Depending on the desired degree of light transmission, the roll-up systems are available with GKD mesh types Tigris, Lago or Sambesi.

GKD-SER roll-up doors are produced in cooperation with Braselmann in Ennepetal, Germany.

Figure 1: Shopping arcade in Pforzheim, mesh type: Tigris, ©GKD/Gögelein

Figure 2: Roller shutter in a canteen in Münster, architect: Vervoorts & Schindler Architekten BDA in Bochum, Germany, mesh type: Tigris, ©GKD/Holtkötter

Figure 3: Cologne Bonn Airport, mesh type: Tigris, © GKD/Rudi Böhmer

MESH TYPES



LAGO



SAMBESI



TIGRIS

MESH	LAGO	SAMBESI	TIGRIS
Material	Stainless steel	Stainless steel	Stainless steel
Free area	44,00 %	42,00 %	65,00 %
Total mesh thickness	3,5 mm	7,0 mm	6,2 mm
Weight	6,8 kg/m ²	10,75 kg/m ²	6,4 kg/m ²
Maximum mesh width	8000 mm	8000 mm	8000 mm
Standard width	6000 mm	6000 mm	6000 mm
Solar factor	g_{total} 0,38, Fc 0,56	g_{total} 0,32, Fc 0,55	g_{total} 0,46, Fc 0,78

GKD stainless steel meshes are durable, completely recyclable and easy to clean using standard commercial cleaning agents (please refer to the GKD cleaning instructions for metal mesh).

EXTERNAL MOTOR AND TUBE MOTOR: DIFFERENCES BETWEEN THE SYSTEMS

External motor systems (400 V) are easy to maintain, as the motor can simply be replaced if damaged. An inspection opening should therefore be provided in the area of the motor. Due to their high performance, units with external motors can also be used for large installations. They are suitable for continuous use in highly frequented areas such as entrances and exits to garages up to a maximum size of 8 x 5 m (maximum of ten cycles per hour, depending on the motor type). External systems can be automated.

Tube motor systems (230 V) are more compact than external drives. But since they offer lower performance and heat up more easily, they are only suitable for systems up to a

maximum width of 6 m (depending on mesh type) and are limited to 5-10 movement cycles per day, between which there should be a break of at least 30 minutes. They are controlled solely via a key switch. Tube motor systems are therefore primarily used for shutters that are only moved relatively rarely, such as those at kiosks or sales areas that are only moved twice per day, i.e. once when opening in the morning and once again when closing in the evening. It should be noted that the entire shaft (including hanger) must be removed in the event of damage to the motor. Depending on the installation situation, this can lead to problems and should be taken into account when designing the system.



EXTERNAL MOTOR

Motor: GFA /TYPE SI 10.15 / 17.15 / 25.15 / 40.15 / 55.15 / 75.15

www.gfa-elektromaten.com



Type	SI 10.15	SI 17.15	SI 25.15	SI 40.15	SI 55.15	SI 75.15
Weight	12,50 kg	15,50 kg	21 kg	28 kg	30 kg	44 kg
Nm	100 Nm	170 Nm	250 Nm	400 Nm	550 Nm	750 Nm
Rpm	15	15	15	15	15	15
Max cycles p. h.*	10	10	10	7	8	7

* When using the temperature range +40 °C to +60 °C, the number of maximum cycles per hour should be halved.

PATENTED SAFETY GEAR IN THE TRANSMISSION

- Safeguard to prevent a broken worm shaft or worm gear
- Not dependent on speed or direction of rotation
- Maintenance-free and self-controlled
- Excellent cushioning characteristics in the event of a catching operation

- Supply voltage: 3-400 V, other motors/voltages available on request
- Model with emergency hand crank

STANDARD CONTROL SYSTEM FOR EXTERNAL DRIVES: GFA TS 959

DEAD MAN'S CONTROL SYSTEM FOR GFA ELEKTROMATEN®
WITH DIGITAL DES LIMIT SWITCH OR NES CAM LIMIT SWITCH



Automatic control system for GfA ELEKTROMATEN® with DES digital limit switch or NES cam limit switch

TESTS AND CERTIFICATES FOR TS 971/ Type approval test as per:

DIN EN 12453
DIN EN 12978
DIN EN 60335-2-103
DIN EN ISO 13849-1
TÜV NORD CERT GmbH

TS 959 – DEAD MAN'S CONTROL SYSTEM FOR DES / NES

SPECIFICATIONS

- For all GfA-ELEKTROMATEN units with DES or NES
- Supply voltage:
 - 1 N~230 V, PE / 3~230 V, PE / 3 N~400 V, PE / 3~400 V, PE
- Operating frequency: 50 / 60 Hz
- Permitted temperature range: -10°C to +50°C

HOUSING

- Dimensions W x H x D [mm]: 155 x 386 x 90
- IP65 with direct connection or IP54 with CEE connector
- Protection against contact thanks to cover over live parts
- Plug-in connection cable to the ELEKTROMATEN, can be plugged in from below or above

MODEL

- Integrated OPEN-STOP-CLOSE controller
- Safety reversing contactor (with 2nd independent shutdown method)

- Settings via rotary selector with digital display
- Plug-in connection technology – connection cable to the ELEKTROMATEN in various lengths
- Independently programmable relay contact, e.g. can be used for green traffic light or ramp release
- Plug-in slack rope and passdoor connection

ACCESSORIES

- Main switch
- Emergency stop button
- Key switch

FUNCTIONS

- Automatic detection of DES or NES
- Change in direction of rotation via keyboard
- Stop position settings (on DES) and settings for all functions from the operating level
- Operating mode selectable:
 - Dead man's switch CLOSE / OPEN
 - Dead man's switch CLOSE / lock OPEN

- Extended dead man's switch CLOSE / lock OPEN
With this function, the operator must press the CLOSE button until the door is completely closed. If the CLOSE button is released before this time, the door will automatically travel to the UP stop position.
- Status and info display (including display of the last 6 errors), with advanced evaluation via Service Kit available as an option (adapter+software)
- Cycle counter (cannot be reset)
- Maintenance cycle counter:
 - Can be adjusted from 1,000 to 99,000 cycles
 - Once the maintenance cycle number is reached, choice between display or switchover to dead man's operation
- Jam monitoring (with DES), the control system detects a door jam and shuts down the drive
- Dynamic runtime monitoring (with NES):
 - Each time a door moves, the runtime between the stop positions is measured and compared against the last reference time
 - If the runtime is exceeded (deviation can be preset), the control system shuts down the drive
- Adjustable force monitoring in OPEN direction (with DES):
 - Self-learning, so no triggering of force monitoring for example when changing the spring tension

CONNEXIONS

TS 959

Art. No. installation plan: 50001664

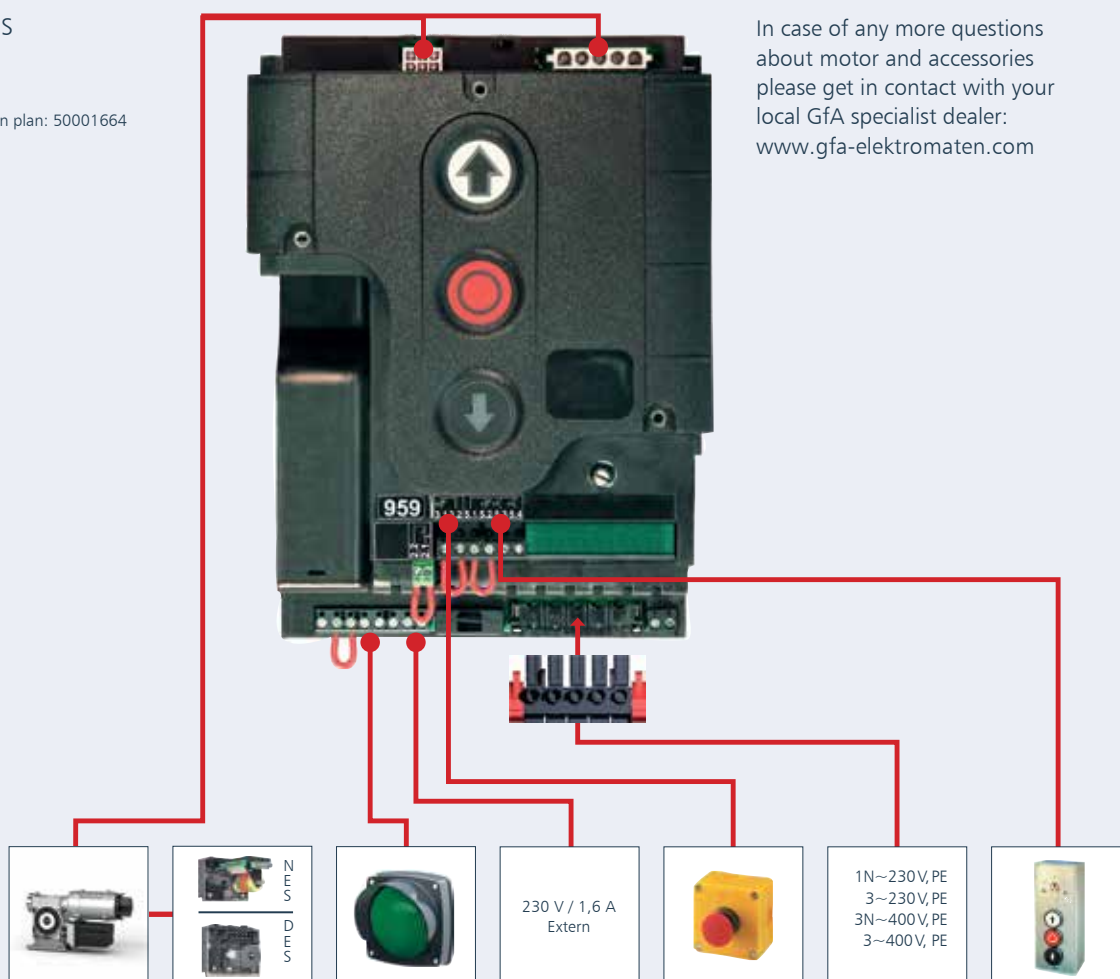

INSTALLATION DIMENSIONS – GFA TS 959 CONTROL SYSTEM

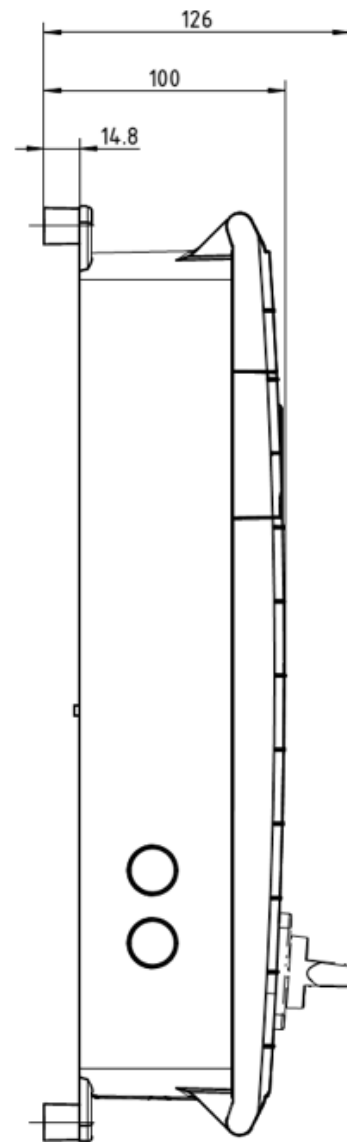
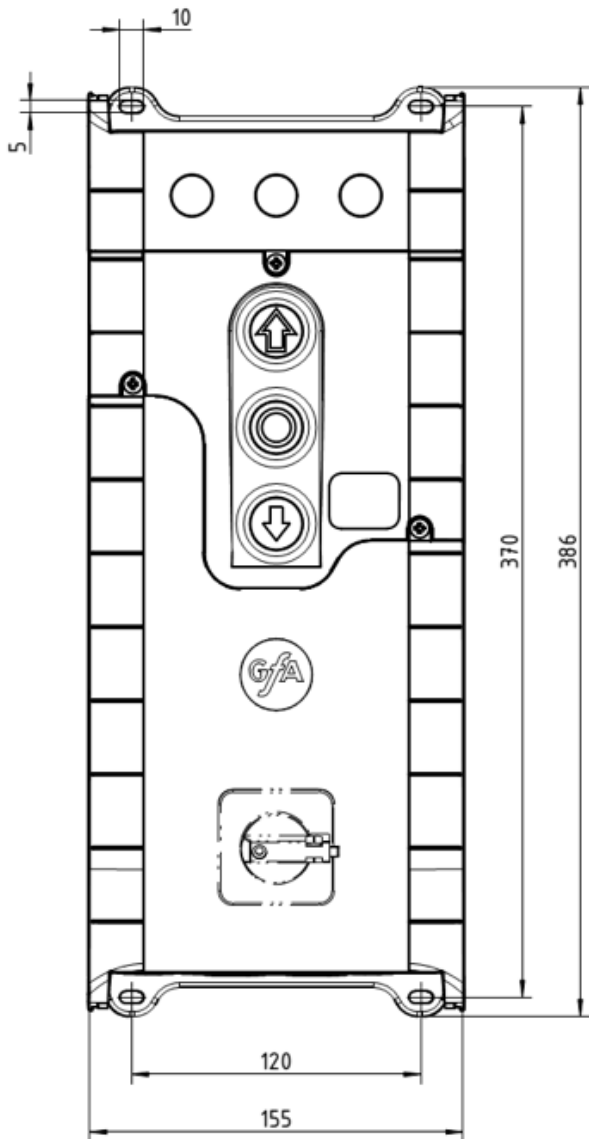

INSTALLATION DIMENSIONS – ROLL-UP DOOR

EXTERNAL MOTOR ON MOTOR SIDE

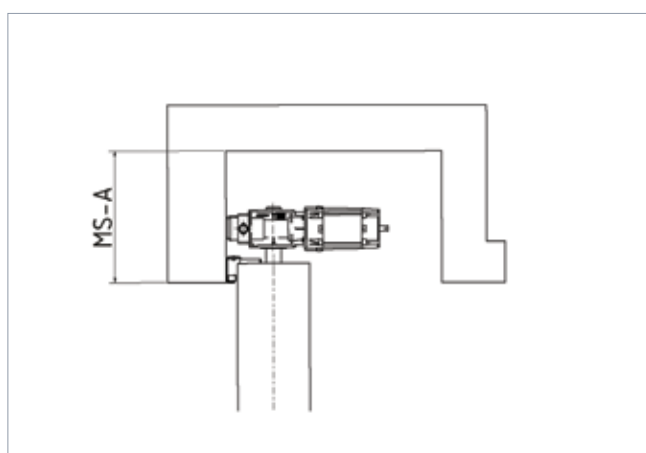

EXTERNAL MOTOR WITH DMS

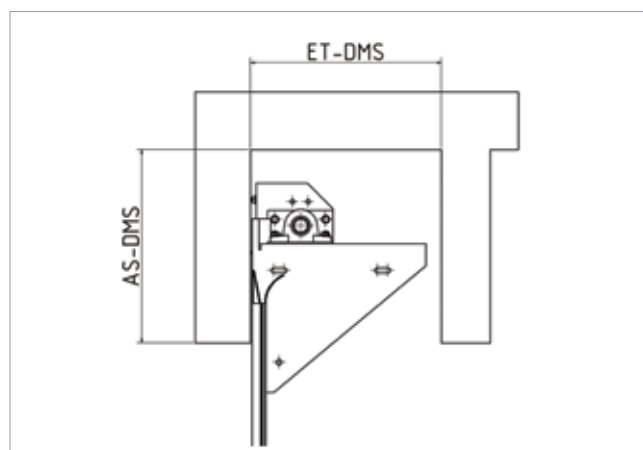
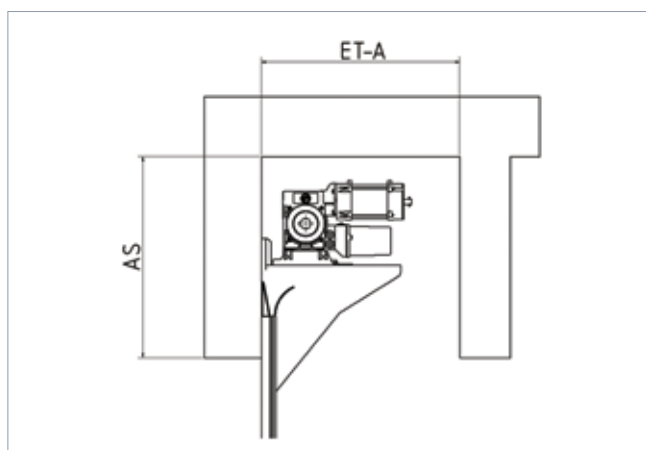
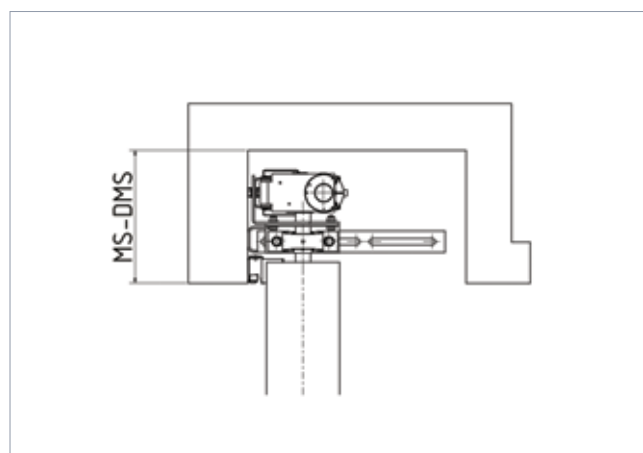

EXTERNAL MOTOR ON BEARING SIDE

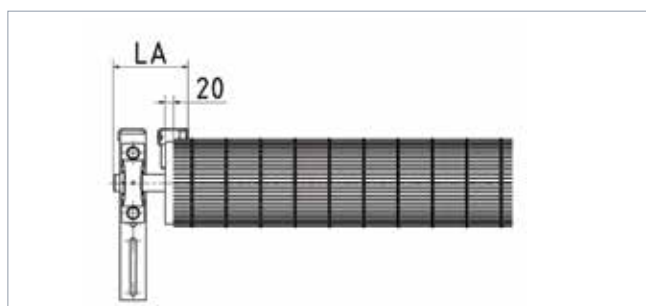

For dimensions, please refer to the reference value tables on pages 12 – 14

SPACE REQUIREMENT FOR GKD ROLL-UP DOOR

EXTERNAL DRIVE

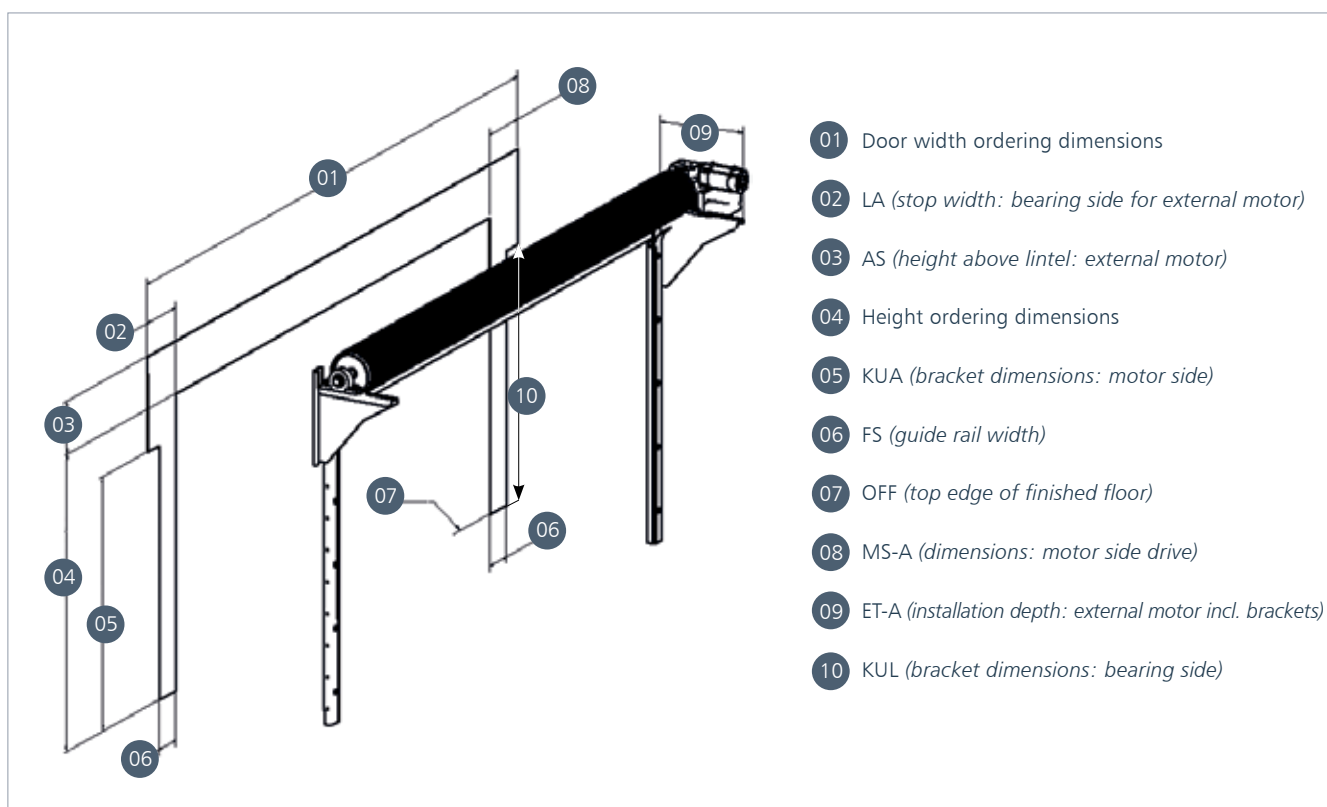

MINIMUM SPACE REQUIREMENTS

Type	SI 10.15	SI 17.15	SI 25.15	SI 40.15	SI 55.15	SI 75.15
Bearing side LA	220 mm	220 mm	220 mm	220 mm	220 mm	260 mm
Motor side MS-A	300 mm	300 mm	300 mm	300 mm	300 mm	320 mm
MS-DMS	380 mm	380 mm	380 mm	380 mm	380 mm	480 mm

Space requirement above lintel AS
Half roll D + 20 mm (air) + 300 mm for a roll Ø of up to 220 mm
Half roll D + 20 mm (air) + 350 mm for a roll Ø of up to 320 mm

EXTERNAL MOTOR INSTALLATION DEPTH SPECIFICATION

Horizontal space requirement for drive, incl. emergency hand crank		
SI 10.15 – 55.15	ET-A	680 mm
SI 75.15	ET-A	950 mm
with DMS (rotated)	ET-DMS	350 mm

CONSOLES

EXTERNAL DRIVE

CONSOLES: 7.0 only SI 10.15 / 7.1 max. 450 kg / 7.5 max. 795 kg

DIMENSIONS OF BRACKET ATTACHMENT 7.0

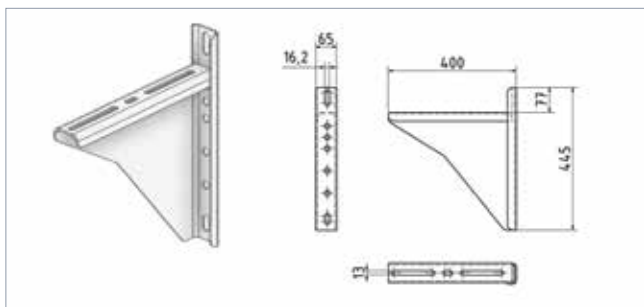

DIMENSIONS OF BRACKET ATTACHMENT 7.1

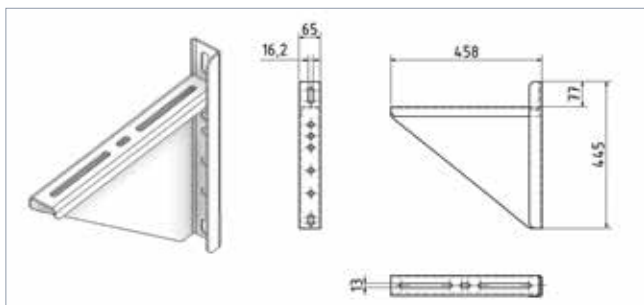

DIMENSIONS OF BRACKET ATTACHMENT 7.5

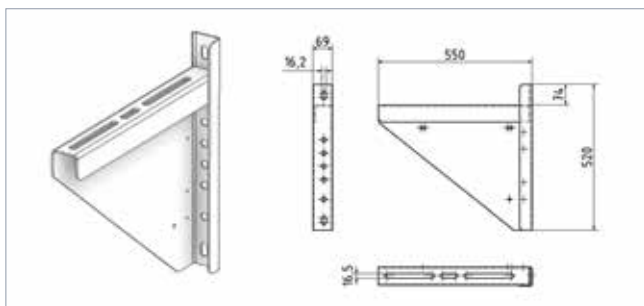

CONSOLE WITH DMS

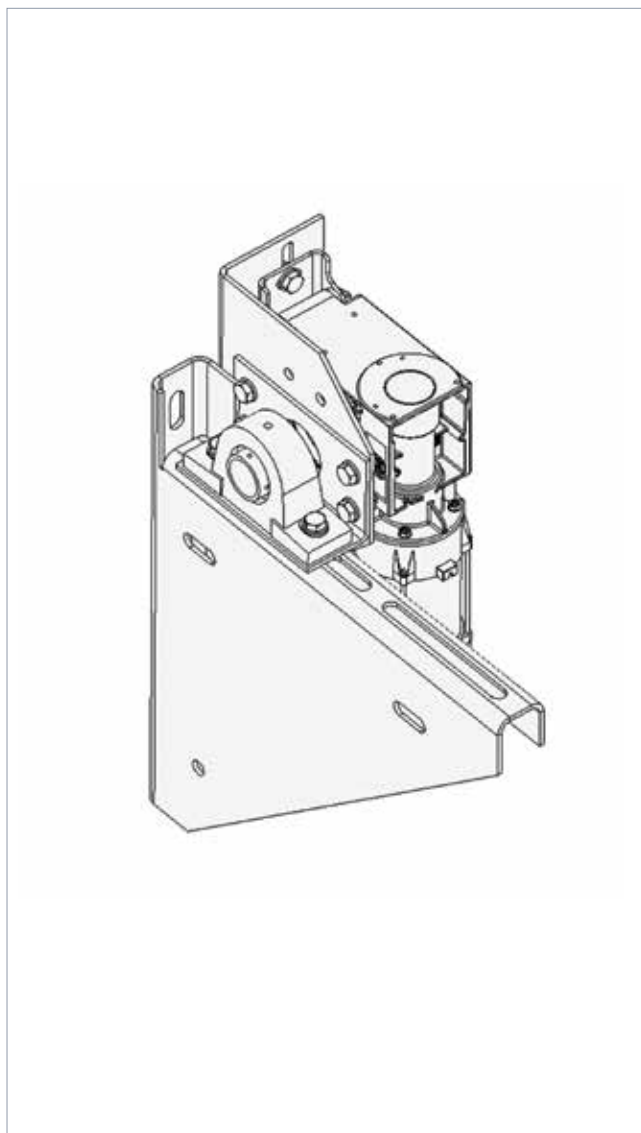

REFERENCE VALUES TABLE: EXTERNAL MOTOR FOR **LAGO** MESH

		EXTERNAL MOTOR LAGO EM MESH											
Type/key	SI 10.15			SI 17.15			SI 25.15			SI 40.15		SI 55.15	
Height	Width										Total weight		
	2 m	2,50 m	3 m	3,50 m	4 m	4,50 m	5 m	6 m	W159 7 m	W178 8 m		Motor type	
2,00 m	89 kg 10.15 200 mm	108 kg 10.15 200 mm	126 kg 10.15 200 mm	145 kg 10.15 200 mm	164 kg 10.15 200 mm	184 kg 17.15 200 mm	203 kg 17.15 200 mm	240 kg 17.15 200 mm	277 kg 17.15 200 mm	351 kg 25.15 215 mm		Roll Ø	
2,50 m	97 kg 10.15 205 mm	117 kg 10.15 205 mm	137 kg 10.15 205 mm	159 kg 10.15 205	181 kg 17.15 205 mm	201 kg 17.15 205 mm	221 kg 17.15 205 mm	362 kg 17.15 205 mm	307 kg 25.15 205 mm	379 kg 25.15 220 mm			
3,00 m	104 kg 10.15 210 mm	126 kg 10.15 210 mm	147 kg 10.15 210 mm	171 kg 17.15 210	195 kg 17.15 210 mm	217 kg 17.15 210 mm	238 kg 17.15 210 mm	288 kg 25.15 210 mm	331 kg 25.15 210 mm	413 kg 40.15 225 mm		W178	
3,50 m	111 kg 10.15 215 mm	136 kg 10.15 215 mm	161 kg 17.15 215 mm	185 kg 17.15 210	209 kg 17.15 215 mm	233 kg 17.15 215 mm	256 kg 17.15 215 mm	308 kg 25.15 215 mm	389 kg 40.15 230 mm	455 kg 40.15 245 mm		W194	
4,00 m	118 kg 10.15 220 mm	145 kg 10.15 220 mm	172 kg 17.15 220 mm	198 kg 17.15 210	223 kg 17.15 220 mm	251 kg 25.15 220 mm	279 kg 25.15 220 mm	329 kg 25.15 220 mm	413 kg 40.15 235 mm	483 kg 40.15 250 mm			
4,50 m	126 kg 10.15 225 mm	154 kg 10.15 225 mm	182 kg 17.15 225 mm	210 kg 17.15 210	237 kg 17.15 225 mm	267 kg 25.15 225 mm	296 kg 25.15 225 mm	350 kg 25.15 225 mm	438 kg 40.15 240 mm	510 kg 40.15 255 mm			
5,00 m	123 kg 10.15 230 mm	158 kg 10.15 230 mm	193 kg 17.15 230 mm	225 kg 17.15 230 mm	256 kg 25.15 230 mm	285 kg 25.15 230 mm	314 kg 25.15 230 mm	378 kg 40.15 230 mm	462 kg 40.15 245 mm	540 kg 55.15 260 mm			
									W159	W178	W194		

REFERENCE VALUES TABLE: EXTERNAL MOTOR FOR **SAMBESI** MESH

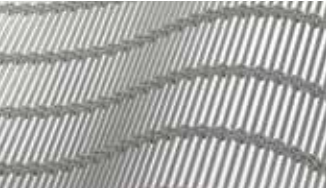

**EXTERNAL MOTOR
SAMBESI EM MESH**

Type/key	SI 10.15	SI 17.15	SI 25.15	SI 40.15	SI 55.15	SI 75.15						
Height	Width								W159	W178	W194	Total weight Motor type Roll Ø
	2 m	2,50 m	3 m	3,50 m	4 m	4,50 m	5 m	6 m	7 m	8 m		
2,00 m	112 kg 10.15 225 mm	137 kg 10.15 225 mm	162 kg 17.15 225 mm	186 kg 17.15 225 mm	210 kg 17.15 225 mm	234 kg 17.15 225 mm	257 kg 17.15 225 mm	310 kg 25.15 225 mm	391 kg 40.15 240 mm	457 kg 40.15 250 mm		
2,50 m	124 kg 10.15 235 mm	152 kg 10.15 235 mm	179 kg 17.15 235 mm	206 kg 17.15 235 mm	233 kg 17.15 235 mm	262 kg 25.15 235 mm	291 kg 25.15 235 mm	344 kg 25.15 235 mm	431 kg 40.15 250 mm	502 kg 40.15 260 mm	W194	
3,00 m	135 kg 10.15 245 mm	166 kg 17.15 245 mm	196 kg 17.15 245 mm	228 kg 17.15 245 mm	260 kg 25.15 245 mm	290 kg 25.15 245 mm	320 kg 25.15 245 mm	385 kg 40.15 245 mm	437 kg 40.15 260 mm	571 kg 55.15 290 mm	W219	
3,50 m	150 kg 17.15 255 mm	182 kg 17.15 255 mm	214 kg 17.15 255 mm	249 kg 25.15 255 mm	283 kg 25.15 255 mm	319 kg 25.15 255 mm	355 kg 40.15 255 mm	418 kg 40.15 255 mm	509 kg 40.15 280 mm	616 kg 55.15 295 mm		
4,00 m	162 kg 17.15 265 mm	200 kg 17.15 265 mm	237 kg 25.15 265 mm	272 kg 25.15 265 mm	306 kg 25.15 265 mm	345 kg 40.15 265 mm	383 kg 40.15 265 mm	475 kg 40.15 275 mm	563 kg 55.15 285 mm	674 kg 75.15 305 mm		
4,50 m	173 kg 17.15 275 mm	214 kg 17.15 275 mm	254 kg 25.15 275 mm	295 kg 25.15 275 mm	336 kg 40.15 275 mm	374 kg 40.15 275 mm	411 kg 40.15 275 mm	511 kg 55.15 285 mm	602 kg 55.15 295 mm	719 kg 75.15 310 mm		
5,00 m	185 kg 17.15 280 mm	228 kg 17.15 280 mm	271 kg 25.15 280 mm	315 kg 25.15 280 mm	358 kg 40.15 280 mm	399 kg 40.15 280 mm	439 kg 40.15 280 mm	545 kg 55.15 295 mm	656 kg 75.15 305 mm	754 kg 75.15 320 mm		
								W159	W178	W194	W219	

REFERENCE VALUES TABLE: EXTERNAL MOTOR FOR **TIGRIS** MESH

		EXTERNAL MOTOR TIGRIS EM MESH												
Type/key		SI 10.15			SI 17.15			SI 25.15			SI 40.15			
Height	Width		2 m	2,50 m	3 m	3,50 m	4 m	4,50 m	5 m	6 m	W159		W178	
	2 m	2,50 m									7 m	8 m		
2,00 m	89 kg	108 kg	126 kg	145 kg	164 kg	184 kg	203 kg	240 kg	277 kg	351 kg	Total weight	Motor type	Roll Ø	
	10.15	10.15	10.15	10.15	10.15	17.15	17.15	17.15	17.15	25.15				
	200 mm	200 mm	200 mm	200 mm	200 mm	200 mm	200 mm	200 mm	200 mm	215 mm				
2,50 m	97 kg	117 kg	137 kg	159 kg	181 kg	201 kg	221 kg	362 kg	307 kg	379 kg				
	10.15	10.15	10.15	10.15	17.15	17.15	17.15	17.15	25.15	25.15				
	205 mm	205 mm	205 mm	205 mm	205 mm	205 mm	205 mm	205 mm	205 mm	220 mm				
3,00 m	104 kg	126 kg	147 kg	171 kg	195 kg	217 kg	238 kg	288 kg	331 kg	413 kg				
	10.15	10.15	10.15	17.15	17.15	17.15	17.15	25.15	25.15	40.15				
	210 mm	210 mm	210 mm	210 mm	210 mm	210 mm	210 mm	210 mm	210 mm	225 mm				
3,50 m	111 kg	136 kg	161 kg	185 kg	209 kg	233 kg	256 kg	308 kg	389 kg	455 kg				
	10.15	10.15	17.15	17.15	17.15	17.15	17.15	25.15	25.15	40.15				
	215 mm	215 mm	215 mm	215 mm	215 mm	215 mm	215 mm	215 mm	230 mm	245 mm			W178	
4,00 m	118 kg	145 kg	172 kg	198 kg	223 kg	251 kg	279 kg	329 kg	413 kg	483 kg				
	10.15	10.15	17.15	17.15	17.15	25.15	25.15	25.15	40.15	40.15				
	220 mm	220 mm	220 mm	220 mm	220 mm	220 mm	220 mm	220 mm	235 mm	250 mm			W194	
4,50 m	126 kg	154 kg	182 kg	210 kg	237 kg	267 kg	296 kg	350 kg	438 kg	510 kg				
	10.15	10.15	17.15	17.15	17.15	25.15	25.15	25.15	40.15	40.15				
	225 mm	225 mm	225 mm	225 mm	225 mm	225 mm	225 mm	225 mm	240 mm	255 mm				
5,00 m	123 kg	158 kg	193 kg	225 kg	256 kg	285 kg	314 kg	378 kg	462 kg	540 kg				
	10.15	10.15	17.15	17.15	25.15	25.15	25.15	40.15	40.15	40.15				
	230 mm	230 mm	230 mm	230 mm	230 mm	230 mm	230 mm	230 mm	245 mm	260 mm				
									W159	W178	W194			

GUIDES AND BOTTOM DOOR EDGE

FOR EXTERNAL MOTOR AND TUBE MOTOR

BOTTOM END PROFILE

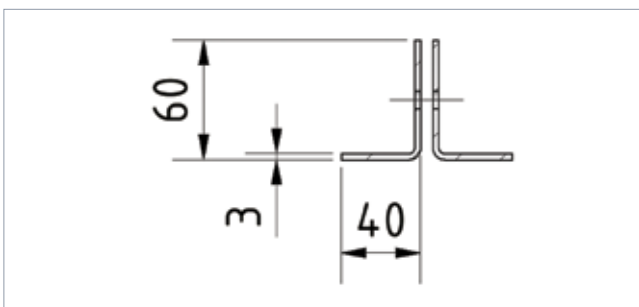

LATERAL GUIDE

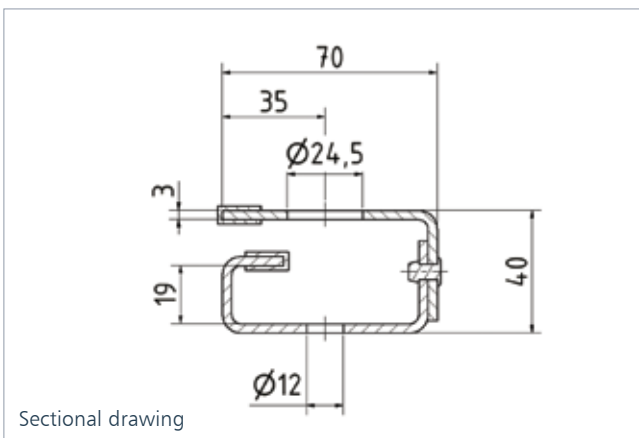
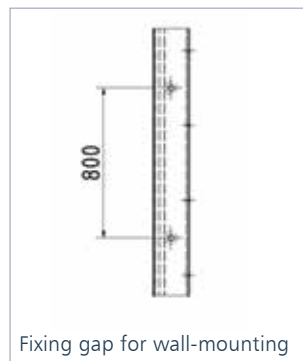
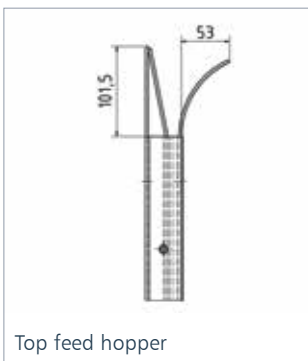

ANGLED BOTTOM PROFILE; EXAMPLE WITH EXTERNAL MOTOR

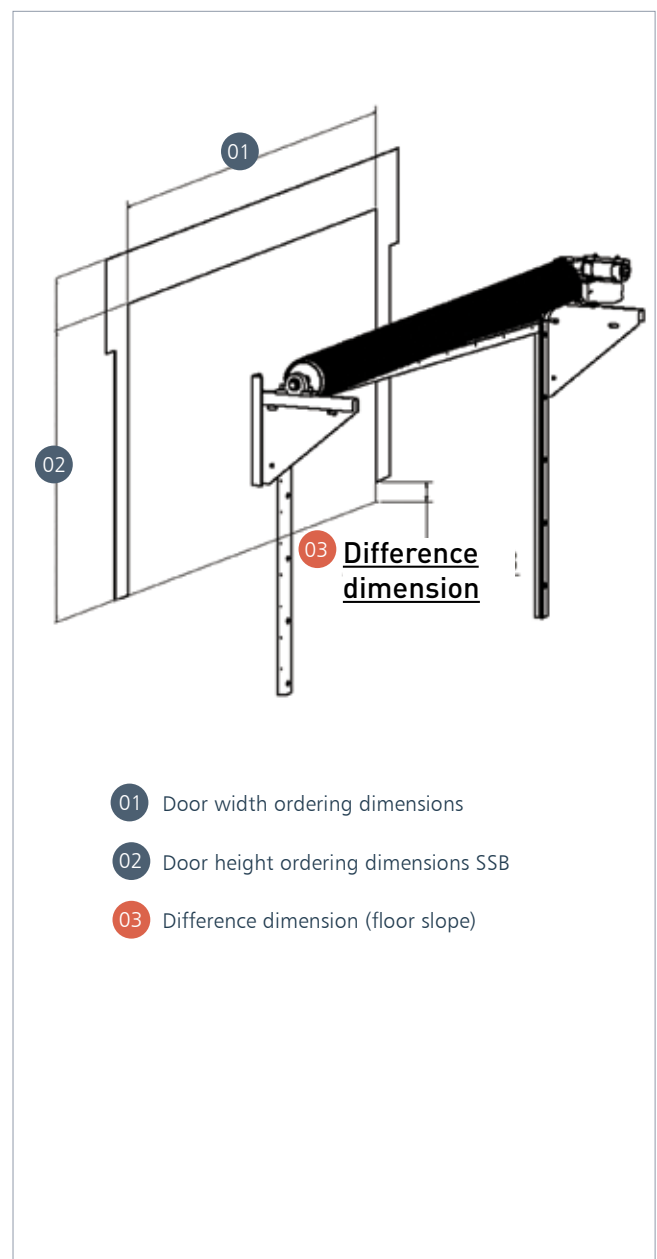

TUBE MOTOR

Motor manufacturer: SIMU / TYP T8S - 150 / 200 / 250

www.simu.com

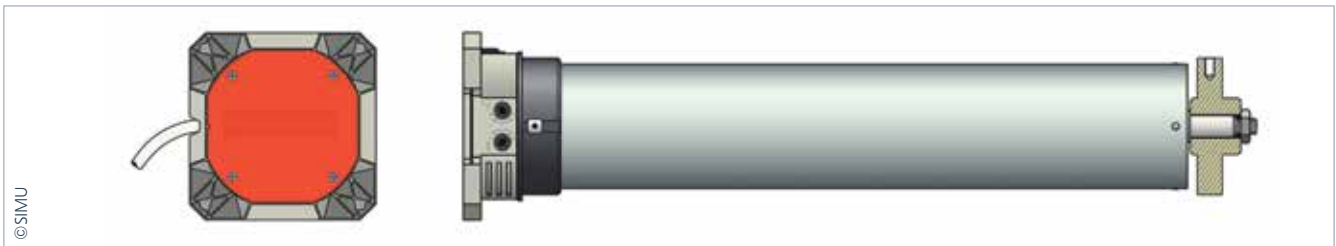

Type	T8S - 150	T8S - 200	T8S - 250
Weight	9,5 kg	11 kg	11,5 kg
Nm	150 Nm	200 Nm	250 Nm
Rpm	8	8	8

- Power supply 230 V
- Including manual override operation

FOR SAFETY: Control system, a third switch interrupts the power supply according to EN 12453.

Thermal shutdown:	4 minutes
T8S DMI reduction ratio of the emergency hand crank:	190/1
Enclosure type:	IP44
Working environment temperature:	from -10 °C to +40 °C, in extreme cases from -20 °C to +60 °C
Supply cable:	2.5 meters (4 x 0.75 mm ² wires, white H05 VVF)
Cycles per day:	10, not consecutive

TUBE MOTOR CONTROL SYSTEM

KEY SWITCH



Measurement: 83 x 83 x 58 mm

WALL-MOUNTED / FLUSH MOUNTED (RECESSED)

– Universal key switch with button and locking function. Operation possible on one or both sides. IP54 enclosure

Order no.	Voltage	Switching capacity	Dimensions
2212079	250V - AC	1 Motor	10A

INSTALLATION DIMENSIONS

TUBE MOTOR ON MOTOR SIDE

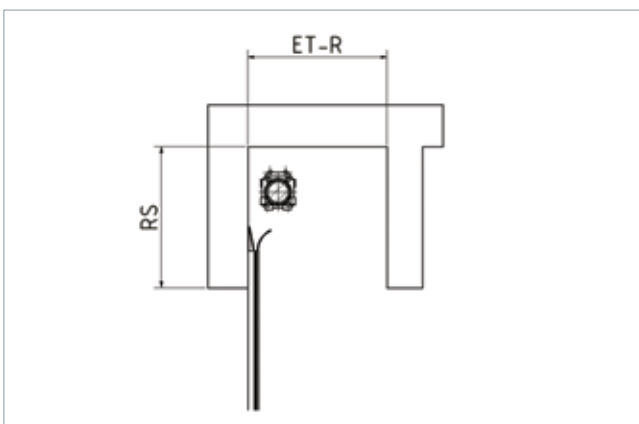

TUBE MOTOR ON BEARING SIDE

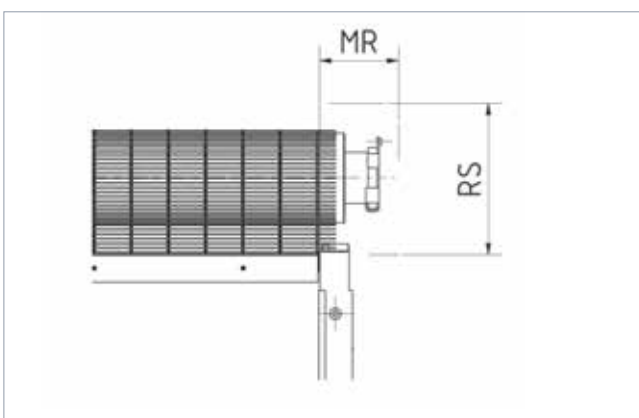
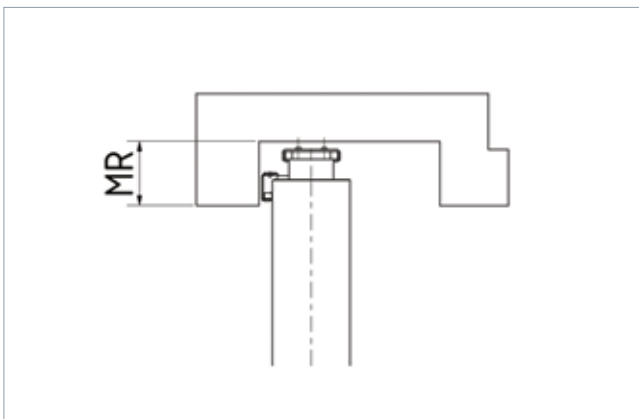
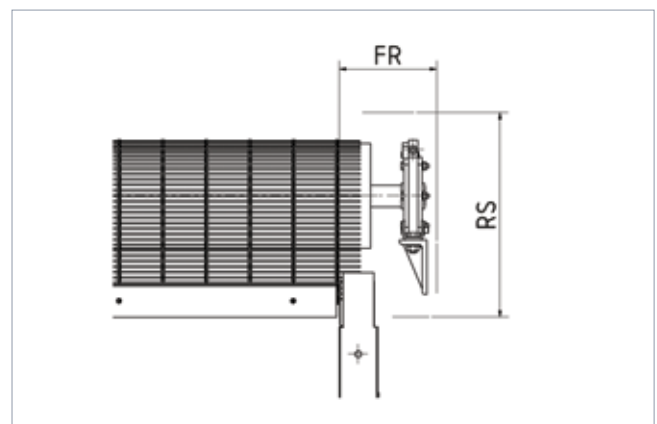

For dimensions, please refer to the reference value tables on pages 20 to 22

SPACE REQUIREMENT FOR GKD ROLL-UP DOOR

TUBULAR DRIVE

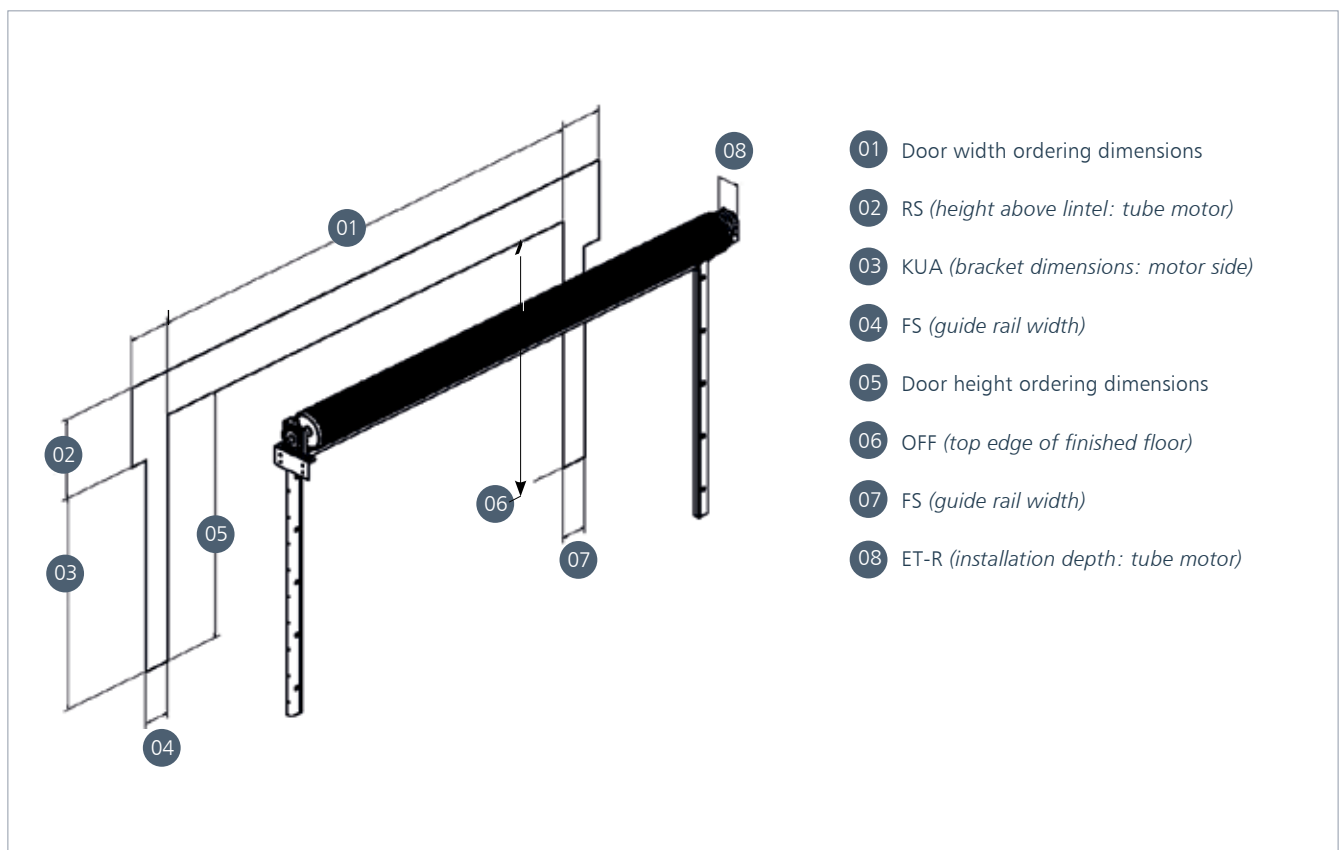

MINIMUM SPACE REQUIREMENTS

Type	T8M 150 Nm	T8M 200 Nm	T8M 250 Nm
Bearing side FR	131 mm	131 mm	131 mm
Motor side MR	159,5 mm	159,5 mm	159,5 mm

Space requirement above lintel RS
Half roll D + 20 mm (air) + 300 mm for a roll Ø of up to 220 mm
Half roll D + 20 mm (air) + 350 mm for a roll Ø of up to 320 mm

CONSOLES

TUBULAR DRIVE

MOTOR CONSOLE

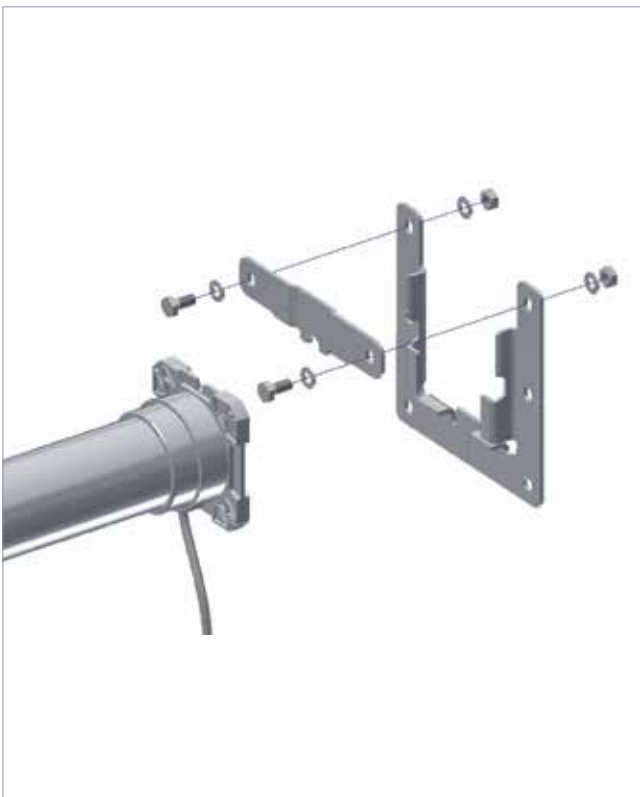

UNROLL SAFEGUARD BRACKET

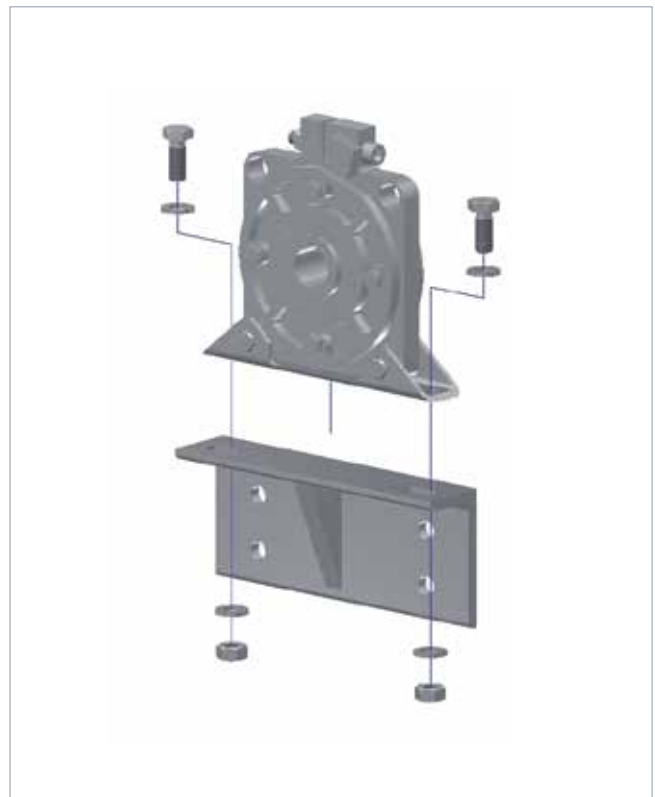

INSTALLATION VERSIONS

On the ceiling

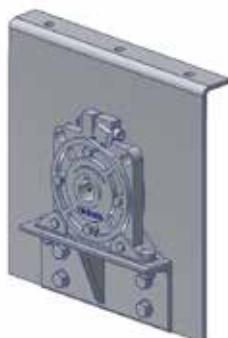

Against the wall

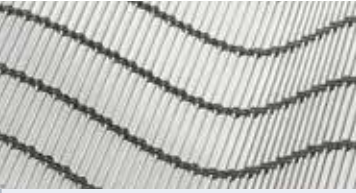

REFERENCE VALUES TABLE: TUBE MOTOR FOR **LAGO** MESH

 TUBE MOTOR LAGO RM MESH									
Type/key	T8M 150Nm			T8M 200Nm			T8M 250Nm		
Height	Width								Total weight Motor type Roll Ø
	2 m	2,50 m	3 m	3,50 m	4 m	4,50 m	5 m	W159 6 m	
2,00 m	89 kg T8M 150Nm 200 mm	108 kg T8M 150Nm 200 mm	126 kg T8M 150Nm 200 mm	145 kg T8M 150Nm 200 mm	164 kg T8M 150Nm 200 mm	182 kg T8M 150Nm 200 mm	200 kg T8M 150Nm 200 mm	237 kg T8M 150Nm 200 mm	
2,50 m	97 kg T8M 150Nm 205 mm	117 kg T8M 150Nm 205 mm	137 kg T8M 150Nm 205 mm	159 kg T8M 150Nm 205 mm	181 kg T8M 150Nm 205 mm	200 kg T8M 150Nm 205 mm	218 kg T8M 150Nm 205 mm	260 kg T8M 200Nm 205 mm	
3,00 m	104 kg T8M 150Nm 210 mm	126 kg T8M 150Nm 210 mm	147 kg T8M 150Nm 210 mm	171 kg T8M 150Nm 210 mm	195 kg T8M 150Nm 210 mm	217 kg T8M 150Nm 210 mm	238 kg T8M 200Nm 210 mm	280 kg T8M 200Nm 210 mm	
3,50 m	111 kg T8M 150Nm 215 mm	136 kg T8M 150Nm 215 mm	161 kg T8M 150Nm 215 mm	185 kg T8M 150Nm 215 mm	209 kg T8M 150Nm 215 mm	232 kg T8M 150Nm 215 mm	254 kg T8M 200Nm 215 mm	301 kg T8M 250Nm 215 mm	
4,00 m	118 kg T8M 150Nm 220 mm	145 kg T8M 150Nm 220 mm	172 kg T8M 150Nm 220 mm	198 kg T8M 200Nm 220 mm	223 kg T8M 200Nm 220 mm	251 kg T8M 200Nm 220 mm	279 kg T8M 200Nm 220 mm	329 kg T8M 250Nm 220 mm	
4,50 m	126 kg T8M 150Nm 225 mm	154 kg T8M 150Nm 225 mm	182 kg T8M 150Nm 225 mm	210 kg T8M 200Nm 225 mm	237 kg T8M 200Nm 225 mm	263 kg T8M 200Nm 225 mm	289 kg T8M 250Nm 225 mm	350 kg T8M 250Nm 225 mm	
5,00 m	123 kg T8M 150Nm 230 mm	158 kg T8M 150Nm 230 mm	193 kg T8M 150Nm 230 mm	225 kg T8M 200Nm 230 mm	256 kg T8M 200Nm 230 mm	283 kg T8M 250Nm 230 mm	310 kg T8M 250Nm 230 mm		
W159									

REFERENCE VALUES TABLE: TUBE MOTOR FOR **SAMBESI** MESH

Type/key		T8M 150Nm			T8M 200Nm			T8M 250Nm			
		Bottom door edge: Angle profile		60x40x3							
Height	Width	2 m	2,50 m	3 m	3,50 m	4 m	4,50 m	5 m	W159 6 m	Total weight	Motor type
2,00 m		112 kg T8M 150Nm 220 mm	135 kg T8M 150Nm 220 mm	159 kg T8M 150Nm 220 mm	183 kg T8M 150Nm 220 mm	206 kg T8M 150Nm 220 mm	230 kg T8M 200Nm 220 mm	255 kg T8M 200Nm 220 mm	303 kg T8M 250Nm 220 mm		Roll Ø
2,50 m		124 kg T8M 150Nm 230 mm	150 kg T8M 150Nm 230 mm	176 kg T8M 150Nm 230 mm	203 kg T8M 150Nm 230 mm	229 kg T8M 200Nm 230 mm	256 kg T8M 200Nm 230 mm	283 kg T8M 200Nm 230 mm	337 kg T8M 250Nm 230 mm		
3,00 m		135 kg T8M 150Nm 240 mm	164 kg T8M 150Nm 240 mm	193 kg T8M 150Nm 240 mm	223 kg T8M 200Nm 240 mm	252 kg T8M 200Nm 240 mm	283 kg T8M 200Nm 240 mm	313 kg T8M 250Nm 240 mm			
3,50 m		147 kg T8M 150Nm 250 mm	180 kg T8M 150Nm 250 mm	212 kg T8M 200Nm 250 mm	244 kg T8M 200Nm 250 mm	276 kg T8M 250Nm 250 mm	295 kg T8M 250Nm 250 mm				
4,00 m		159 kg T8M 150Nm 260 mm	194 kg T8M 150Nm 260 mm	229 kg T8M 200Nm 260 mm	264 kg T8M 200Nm 260 mm	299 kg T8M 250Nm 260 mm					
4,50 m		170 kg T8M 150Nm 270 mm	208 kg T8M 200Nm 270 mm	246 kg T8M 200Nm 270 mm	273 kg T8M 250Nm 270 mm						
5,00 m		182 kg T8M 150Nm 280 mm	223 kg T8M 200Nm 280 mm	264 kg T8M 250Nm 280 mm							
W159											

REFERENCE VALUES TABLE: TUBE MOTOR FOR **TIGRIS** MESH

		T8M 150Nm			T8M 200Nm			T8M 250Nm			
Type/key											
Height	Width								W159		Total weight Motor type Roll Ø
	2 m	2,50 m	3 m	3,50 m	4 m	4,50 m	5 m	6 m			
2,00 m	85 kg T8M 150Nm 200 mm	103 kg T8M 150Nm 200 mm	120 kg T8M 150Nm 200 mm	138 kg T8M 150Nm 200 mm	155 kg T8M 150Nm 200 mm	174 kg T8M 150Nm 200 mm	193 kg T8M 150Nm 200 mm	228 kg T8M 150Nm 200 mm			
2,50 m	92 kg T8M 150Nm 205 mm	111 kg T8M 150Nm 205 mm	129 kg T8M 150Nm 205 mm	149 kg T8M 150Nm 205 mm	168 kg T8M 150Nm 205 mm	188 kg T8M 150Nm 205 mm	208 kg T8M 150Nm 205 mm	246 kg T8M 150Nm 205 mm			
3,00 m	98 kg T8M 150Nm 210 mm	119 kg T8M 150Nm 210 mm	139 kg T8M 150Nm 210 mm	161 kg T8M 150Nm 210 mm	183 kg T8M 150Nm 210 mm	204 kg T8M 150Nm 210 mm	224 kg T8M 150Nm 210 mm	264 kg T8M 200Nm 210 mm			
3,50 m	104 kg T8M 150Nm 215 mm	126 kg T8M 150Nm 215 mm	148 kg T8M 150Nm 215 mm	172 kg T8M 150Nm 215 mm	196 kg T8M 150Nm 215 mm	210 kg T8M 150Nm 215 mm	239 kg T8M 200Nm 215 mm	289 kg T8M 200Nm 215 mm			
4,00 m	111 kg T8M 150Nm 220 mm	136 kg T8M 150Nm 220 mm	160 kg T8M 150Nm 220 mm	184 kg T8M 150Nm 220 mm	208 kg T8M 150Nm 220 mm	224 kg T8M 200Nm 220 mm	255 kg T8M 200Nm 220 mm	307 kg T8M 250Nm 220 mm			
4,50 m	117 kg T8M 150Nm 230 mm	144 kg T8M 150Nm 230 mm	170 kg T8M 150Nm 230 mm	195 kg T8M 150Nm 230 mm	220 kg T8M 150Nm 230 mm	238 kg T8M 200Nm 230 mm	276 kg T8M 200Nm 230 mm	326 kg T8M 250Nm 230 mm			
5,00 m	124 kg T8M 150Nm 240 mm	152 kg T8M 150Nm 240 mm	179 kg T8M 150Nm 240 mm	265 kg T8M 200Nm 240 mm	233 kg T8M 200Nm 240 mm	255 kg T8M 200Nm 240 mm	291 kg T8M 200Nm 240 mm	344 kg T8M 250Nm 240 mm			
W159											

GUIDES AND BOTTOM DOOR EDGE

FOR EXTERNAL MOTOR AND TUBE MOTOR

BOTTOM END PROFILE

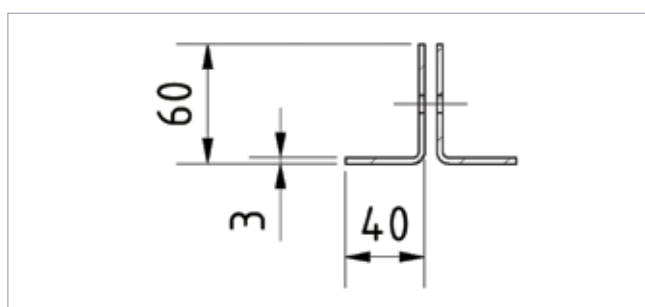

LATERAL GUIDE

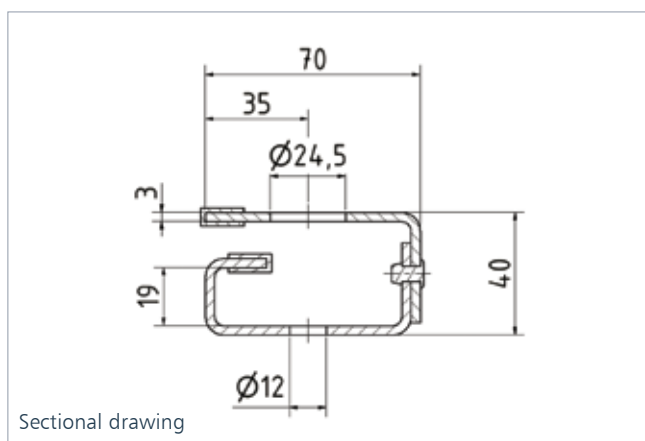
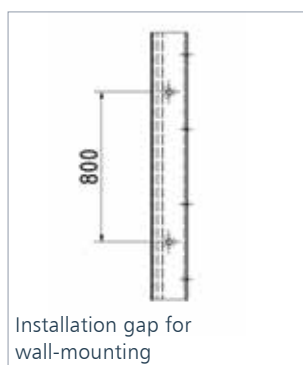
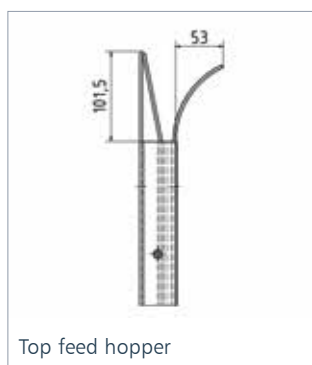

ANGLED BOTTOM PROFILE, EXAMPLE WITH EXTERNAL MOTOR

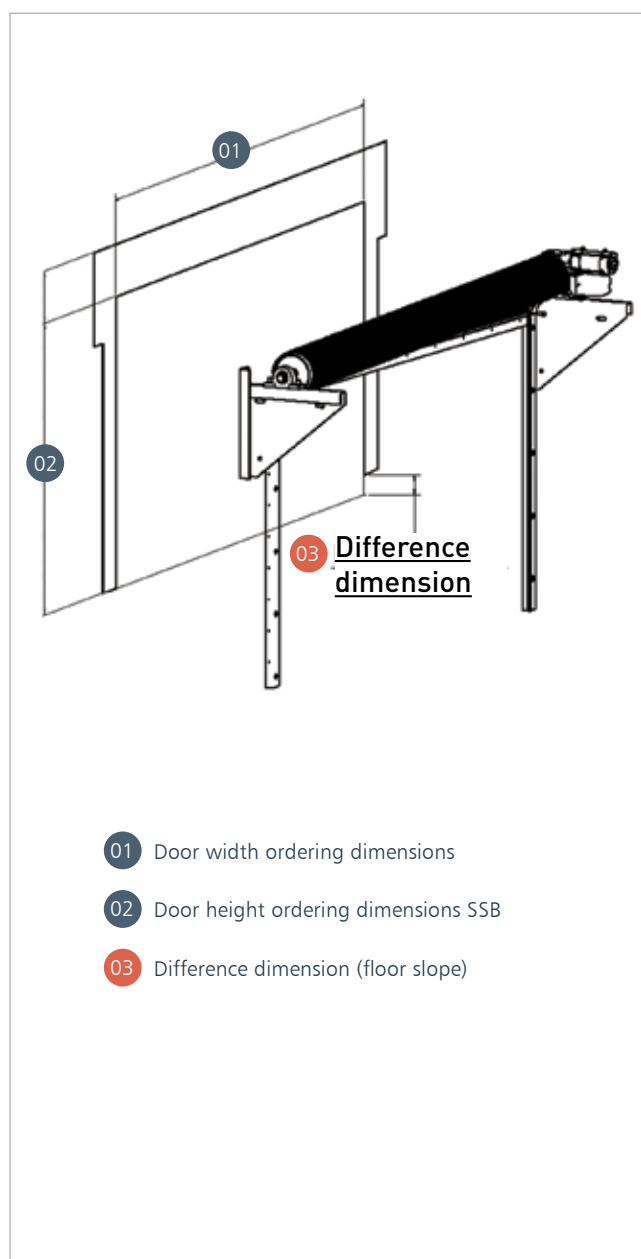

- 01 Door width ordering dimensions
- 02 Door height ordering dimensions SSB
- 03 Difference dimension (floor slope)

GKD – GEBR. KUFFERATH AG

Metallweberstraße 46
52353 Düren
Germany
T +49 (0) 2421 803 - 0
F +49 (0) 2421 803 - 227
info@gkd.de
www.gkd.de

GKD-USA, INC.

825 Chesapeake Drive
Cambridge, MD 21613
U.S.A.
T +1 410 221 0542
F +1 410 221 0544
sales@gkdusa.com
www.gkdusa.com

GKD (UK) LTD.

Genesis 4, Church Lane,
Heslington York
North Yorkshire YO10 5DQ
Great Britain
T +44 (0) 1904 420 500
F +44 (0) 1904 420 509
sales@gkd.uk.com
www.gkd.uk.com

GKD (BEIJING) IND. TECHNOLOGIES CO., LTD.

No. 11, Jinma Industrial Zone,
Middle Road, Shunyi District
101318 Beijing
P.R. China
T +86 10 516 596 18
F +86 10 694 976 01
gkd@gkd-china.com
www.gkd-china.com

TEAM FRANCE SARL

Rue Gutenberg, Zac du Grand Pont
13640 La Roque d'Anthéron
France
T +33 (0) 442 50 70 29
F +33 (0) 442 50 71 40
teamfrance@gkd.fr
www.gkd.fr

FINSA ARQUITECTURA, S.L.

Joan Monpeó 144
08223 Barcelona
Spain
T +34 93 786 1861
F +34 93 785 8359
finsa@finsa-arquitectura.com
www.finsa-arquitectura.com

GKD BUISMET (PTY) LTD.

Aureus Ext. 3, Cnr. Fiat and Chrysler Streets
RSA-1759 Randfontein
South Africa
P.O. Box 6175
RSA-1767 Greenhills
South Africa
T +27 (0) 11 412 47 70
F +27 (0) 11 412 48 23
gkdrsa@gkd.co.za

GKD MIDDLE EAST

Office 1308 Fortune Tower
Jumeirah Lakes Towers
P.O. Box 112410
Dubai
United Arab Emirates
T +971 4 375 70 70
F +971 4 427 04 20
dubai@gkd.de

GKD INDIA LTD.

52, Industrial Area Jhotwara
Jaipur - 302012, Rajasthan
India
T +91 141 710 51 00
F +91 141 710 51 99
query@gkd-india.com
www.gkd-india.com

GKD LatAm S.A.

La Estera 418
Lampa, Santiago
Chile
T +56 2 2489 1040
F +56 2 2489 1031
info@gkd-latam.com
www.gkd-latam.com